

WR-6 Recessed Waste Receptacle

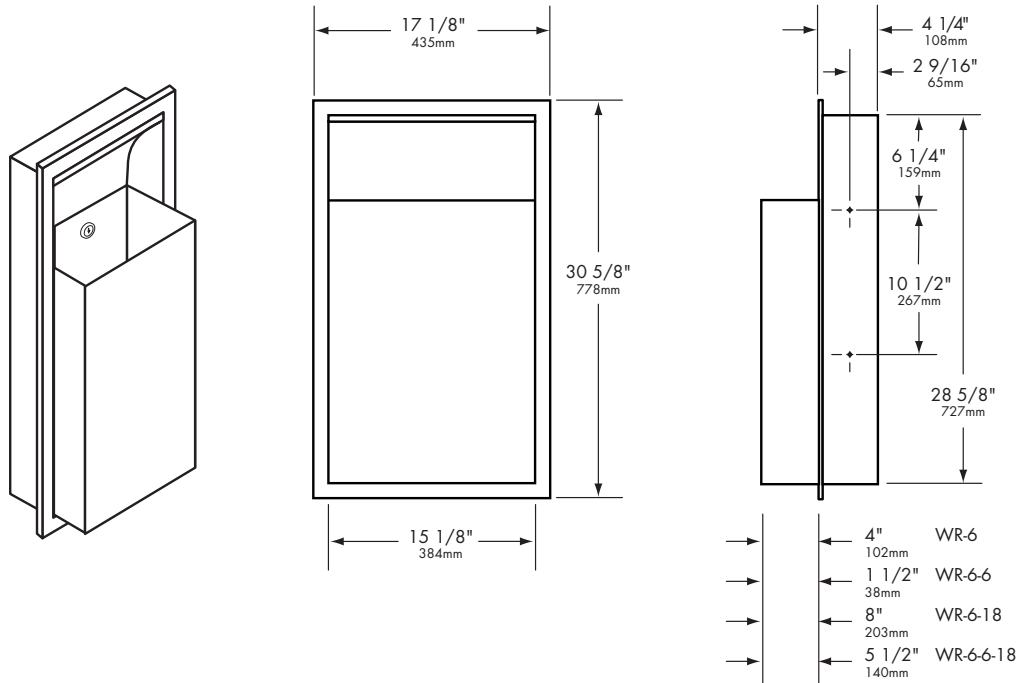

Construction:

Fabricated 18-8 type 304 stainless steel with exposed surfaces #4 satin finished. One piece seamless 22 gauge (0.8mm) flange provided with 1/4" (6mm) return for rigidity. Waste receptacle is 22 gauge (0.8mm) and secured to cabinet with tumbler lock and is removable for servicing. Hemmed top and bottom edges for safety. All welded construction. 12 gallon capacity

Installation:

Provide framed wall opening. Recessed depth required from finish face of wall is 4" (102mm). Check plans and coordinate with mechanical engineer to avoid protrusion from opposite wall, pipes, conduits, electrical wiring etc. If installing in plaster wall recommend grounding. If installing where unit projects above top of wainscot, provide filler to prevent gap from finished wall and flange of unit. Installing in block walls use metal expansion shields. 1/8" (3mm) gap recommended between units for door clearance.

Overall Dimensions:

17-3/16"W x 30-5/8"H x 4"D
435mm x 778mm x 102mm

Wall Opening:

15-3/4"W x 29-1/8"H x 4"D
400mm x 740mm x 102mm

Mounting:

51" (1,295mm) to top of unit, 37" (940mm) for handicapped

ADA Guide:

Access to paper towels should be 15" (381mm) to 48" (1,219mm) above the finish floor to allow forward and side reach by people in wheelchairs. Hinged panels covering waste receptacle openings should not require more than 5 pounds of force to open. Units should not project more than 4" (102mm) from the wall. Operable with one hand and without tight grasping, pinching, or twisting of the wrist. Activation of lever should not require more than 5 pounds of force when unit is completely filled.

Manufacturer reserves the right to make changes in design or dimensions without formal notice.