

WR-15 Waste Receptacle

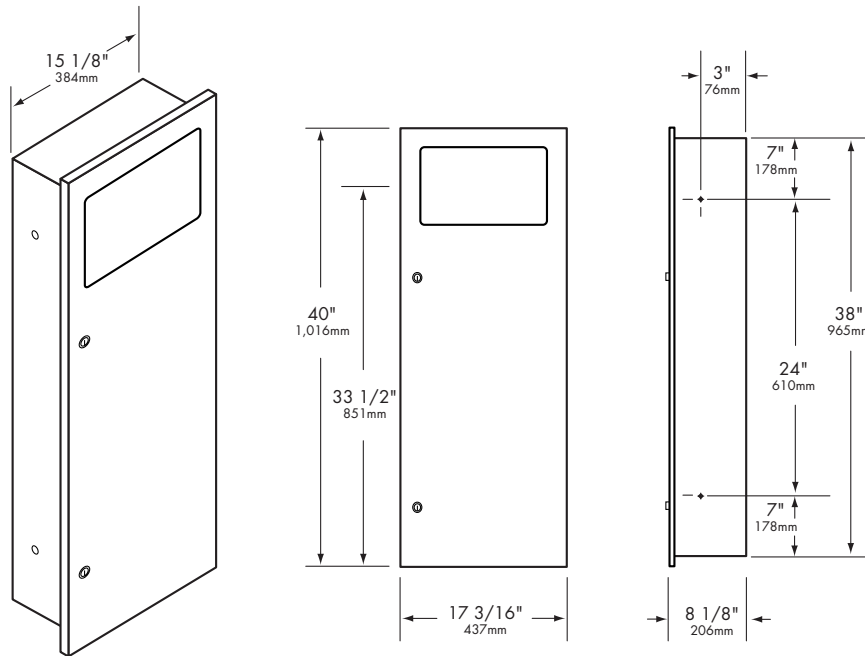

Construction:

Fabricated 18-8 type 304 stainless steel with exposed surfaces #4 satin finished. One piece seamless door construction, extra heavy 18 gauge (1.2mm) with 5/8" (16mm) return for rigidity. Door is mounted to cabinet with continuous stainless steel piano hinge and fitted with two tumbler locks. All welded construction. Plastic inner container capacity is 12 gallons.

Installation:

Provide framed wall opening. Recessed depth required from finish face of wall is 7-3/4" (197mm). Check plans and coordinate with mechanical engineer to avoid protrusion from opposite wall, pipes, conduits, electrical wiring etc. If installing in plaster wall recommend grounding. If installing where unit projects above top of wainscot, provide filler to prevent gap from finished wall and flange of unit. Installing in block walls use metal expansion shields.

Overall Dimensions:

17-3/16"W x 40"H x 8-1/8"D
437mm x 1,016mm x 206mm

Wall Opening:

15 5/8"W x 38-1/2"H x 7-3/4"D
397mm x 978mm x 197mm

Mounting:

44" (1,118mm) to top of unit

ADA Guide:

Access to paper towels should be 15" (381mm) to 48" (1,219mm) above the finish floor to allow forward and side reach by people in wheelchairs. Hinged panels covering waste receptacle openings should not require more than 5 pounds of force to open. Units should not project more than 4" (102mm) from the wall.

Options:

WR-15F Same as WR-15 except with 4" (102mm) skirt for semi-recessing
WR-15FS Same as WR-15 except with 7-3/4" (197mm) skirt for surface mounting

Manufacturer reserves the right to make changes in design or dimensions without formal notice.