

FLOOR STANDING SWING-TOP WASTE RECEPTACLE

WR-SERIES FLOOR STANDING

OPTIONS: *add suffix:*

- VL for waste receptacle with liners;
hooks for liners are optional

Date:

Project Name:

AVAILABLE SIZES

Model No.	Capacity		Length		Width		Height	
WR-11	13-gallon	42.3-L	12-1/2"	318mm	12-1/2"	318mm	29-1/2"	749mm
WR-12	21-gallon	79.5-L	14"	358mm	14"	358mm	37-1/2"	953mm
WR-13	36-gallon	136.8-L	18"	457mm	18"	457mm	37-1/2"	953mm
WR-11NT	13-gallon	42.3-L	12-1/2"	318mm	12-1/2"	318mm	23"	584mm
WR-12NT	21-gallon	79.5-L	14"	358mm	14"	358mm	30"	762mm
WR-13NT	36-gallon	136.8-L	18"	457mm	18"	457mm	30"	762mm

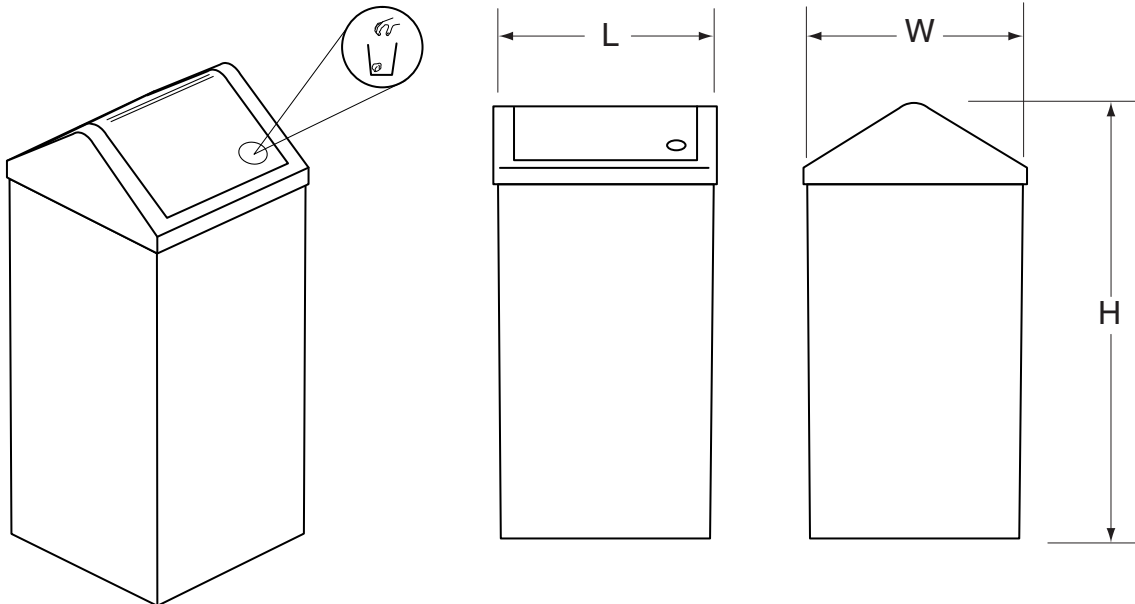

CONSTRUCTION:

Fabricated of type 304 heavy gauge stainless steel. All welded construction with exposed surfaces having a #4 satin-finish. Top has self-closing doors. Rubber feet provided.

Floor Standing Swing-Top Waste Receptacle shall be Model _____ (insert model and option) of GAMCO Commercial Restroom Accessories, A Division of Bobrick, One Gamco Place, Durant, OK 74701-1910, Tel: 1-800-451-5766, Web: www.GAMCOUSA.com