

Date:

Project Name:

**TW-4F** with 2" (51mm) skirt for semi-recess  
**TW-4FS** with 4" (102mm) skirt for surface-mounting

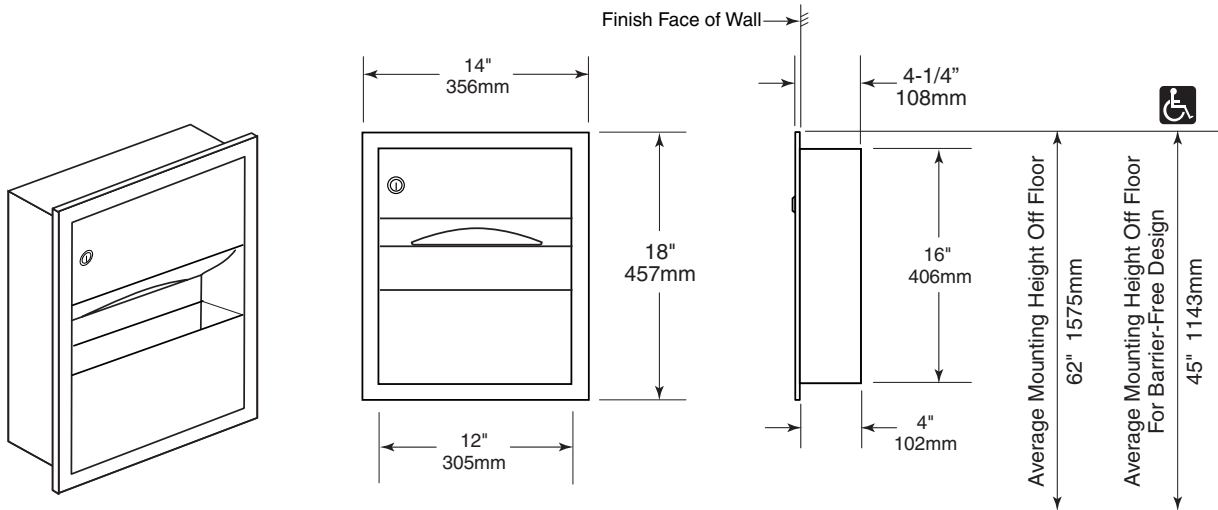

**CONSTRUCTION:**

Fabricated of 22-gauge (0.8mm) type 304 stainless steel. All welded construction with exposed surfaces having a #4 satin finish. One piece seamless flange provided with 1/4" (6mm) return for rigidity. Door mounted to cabinet with continuous stainless steel piano hinge. Waste receptacle is removable for servicing.

**CAPACITY:**

120 C-fold or 200 multi-fold towels.

**INSTALLATION:**

Provide framed wall opening. Recessed depth required from finish face of wall is 4" (102mm). Check plans and coordinate with mechanical engineer to avoid protrusion from opposite wall, pipes, conduits, electrical wiring etc. If installing in plaster wall, recommend grounding. If installing where unit projects above top of wainscot, provide filler to prevent gap from finished wall and flange of unit. If installing in block walls, use metal expansion shields. 1/8" (3mm) gap recommended between units for door clearance.

**OVERALL DIMENSIONS:**

14" W x 18" H x 4-1/4" D (356 x 457 x 102mm)

**ADA GUIDE:**

Access to paper towels should be 15" to 48" (381 to 1219mm) above the finish floor to allow forward and side reach by people in wheelchairs. Units should not project more than 4" (102mm) from the wall.

**Recessed Mini-Towel Dispenser and Waste Receptacle Combination shall be Model TW-4 of GAMCO Commercial Restroom Accessories, A Division of Bobrick, One Gamco Place, Durant, OK**