

Date:

Project Name:

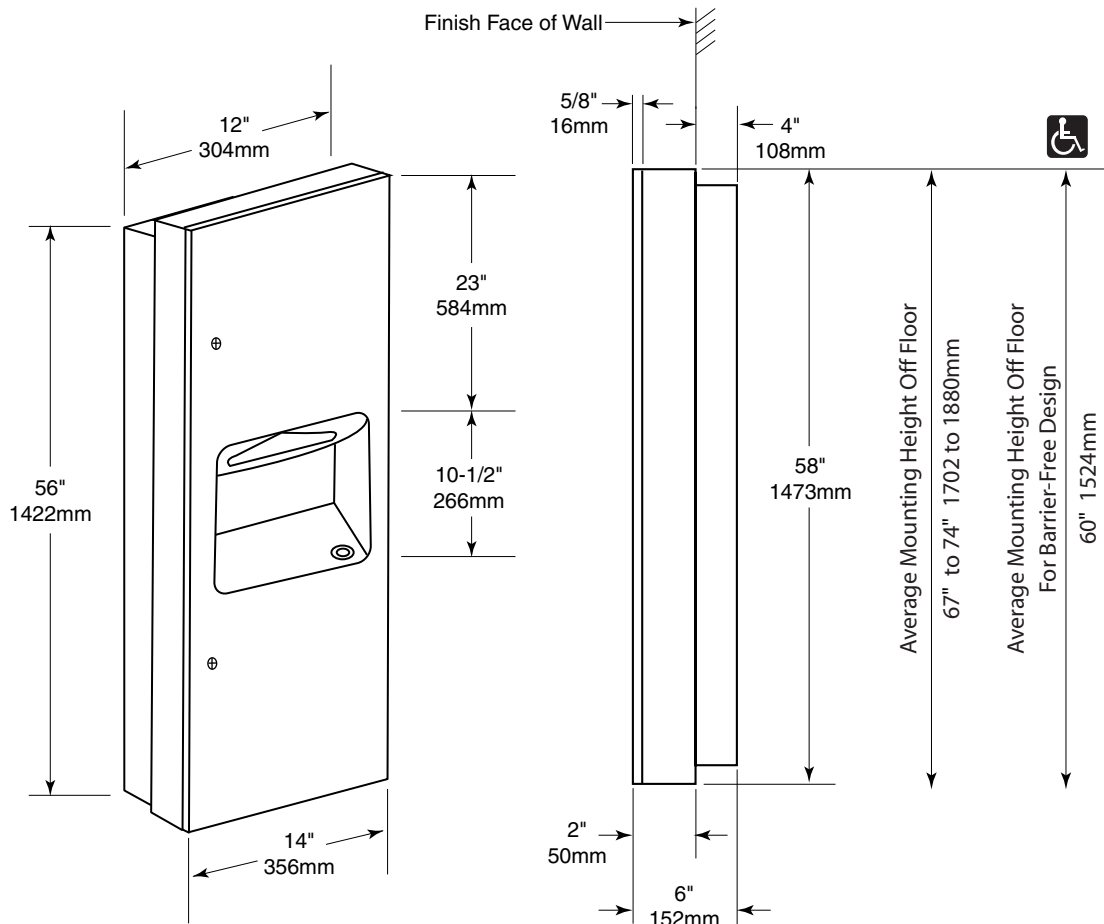

CONSTRUCTION:

Unit fabricated of type 304 stainless steel with exposed surfaces having a satin finish. One piece seamless door construction, EXTRA HEAVY 18-gauge (1.2mm) with 5/8" (16mm) return for rigidity. Door is mounted to cabinet with continuous stainless steel piano hinge and fitted with two tumbler locks. Self-closing push door mounted on continuous stainless steel piano hinge with international symbol. Waste receptacle is 24-gauge (0.6mm). Capacity 5-1/2-gallons (20.8-L). All welded construction.

ADA GUIDE:

Access to paper towels should be 15" to 48" (381 to 1219mm) above the finish floor to allow forward and side reach by people in wheelchairs. Hinged panels covering waste receptacle openings should not require more than 5 pounds of force to open. Units should not project more than 4" (102mm) from the wall.

Semi-Recessed Towel Dispenser and Waste Receptacle Combination shall be Model TW-2F of GAMCO Commercial Restroom Accessories, A Division of Bobrick, One Gamco Place, Durant, OK