

Date:

Project Name:

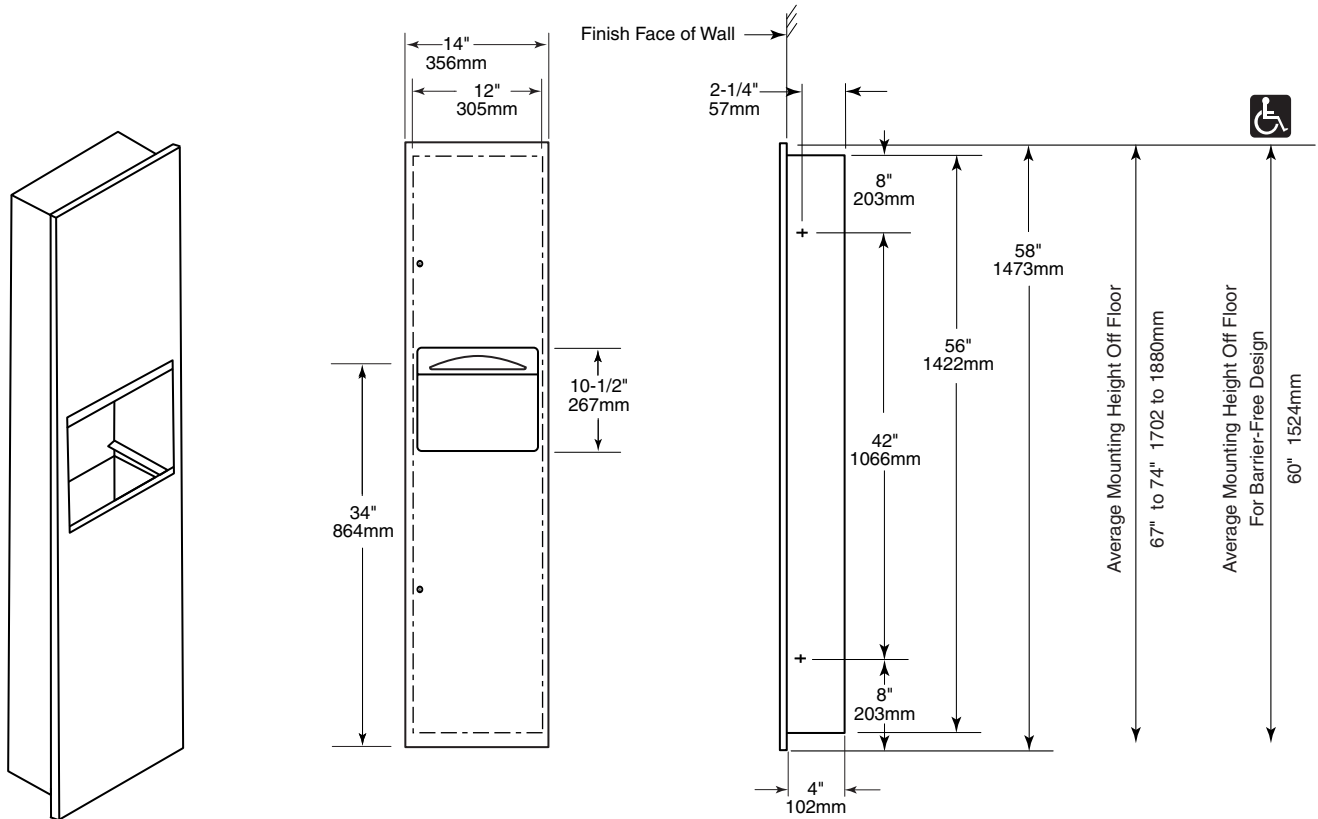

**Rough Wall Opening**

12-1/2" (317mm) wide  
56-1/2" (1435mm) high  
4" (102mm) minimum  
recessed depth

**CONSTRUCTION:**

Unit fabricated of type 304 stainless steel with exposed surfaces having a satin finish. One piece seamless door construction, EXTRA HEAVY 18-gauge (1.2mm) with 5/8" (16mm) return for rigidity. Door is mounted to cabinet with continuous stainless steel piano-hinge and fitted with two tumbler locks. Stainless steel waste container, 4 -1/2-gallon (17-L) capacity.

**CAPACITY:**

600 C-fold or 800 multi-fold (will not dispense single-fold towels)

**OVERALL DIMENSIONS:**

14" W x 58" H x 4" D (355 x 1473 x 102mm)

**Recessed Coverall Towel Dispenser and Waste Receptacle Combination shall be Model TW-2-4 of GAMCO Commercial Restroom Accessories, A Division of Bobrick, One Gamco Place, Durant, OK**