

Date:

Project Name:

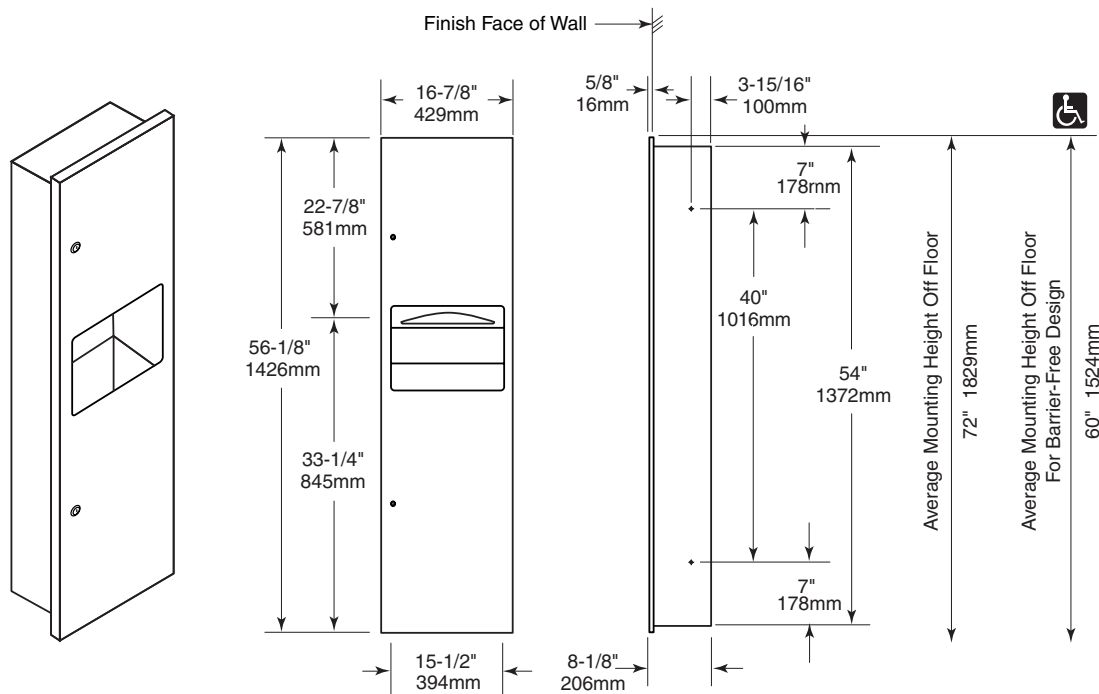

<p>Rough Wall Opening 16" (406mm) Wide 54-1/2" (1384mm) High 7-3/4" (197mm) minimum recessed depth</p>

CONSTRUCTION:

Fabricated of type 304 stainless steel. All welded construction with exposed surfaces having a #4 satin-finish. One piece seamless door construction, EXTRA HEAVY 18-gauge (1.2mm) with 5/8" (16mm) return for rigidity. Door is mounted to cabinet with continuous stainless steel piano hinge and fitted with two tumbler locks. Waste receptacle is 24-gauge (0.6mm), with 12-gallon (45.4-L) capacity. 600 C-fold, 800 multi-fold or 1100 single-fold towels. All welded construction.

INSTALLATION:

Provide framed wall opening. Recessed depth required from finish face of wall is 7-3/4" (197mm). Check plans and coordinate with mechanical engineer to avoid protrusion from opposite wall, pipes, conduits, electrical wiring etc. If installing in plaster wall, recommend grounding. If installing where unit projects above top of wainscot, provide filler to prevent gap from finished wall and flange of unit. If installing in block walls, use metal expansion shields.

OVERALL DIMENSIONS:

16-7/8" W x 56-1/8" H x 8-1/8" D (429 x 1426 x 206mm)

ADA GUIDE:

Access to paper towels should be 15" to 48" (381 to 1219mm) above the finish floor to allow forward and side reach by people in wheelchairs. Units should not project more than 4" (102mm) from the wall.

Recessed Coverall Towel Dispenser and Waste Receptacle Combination shall be Model TW-11 of GAMCO Commercial Restroom Accessories, A Division of Bobrick, One Gamco Place, Durant, OK