

Date:

Project Name:

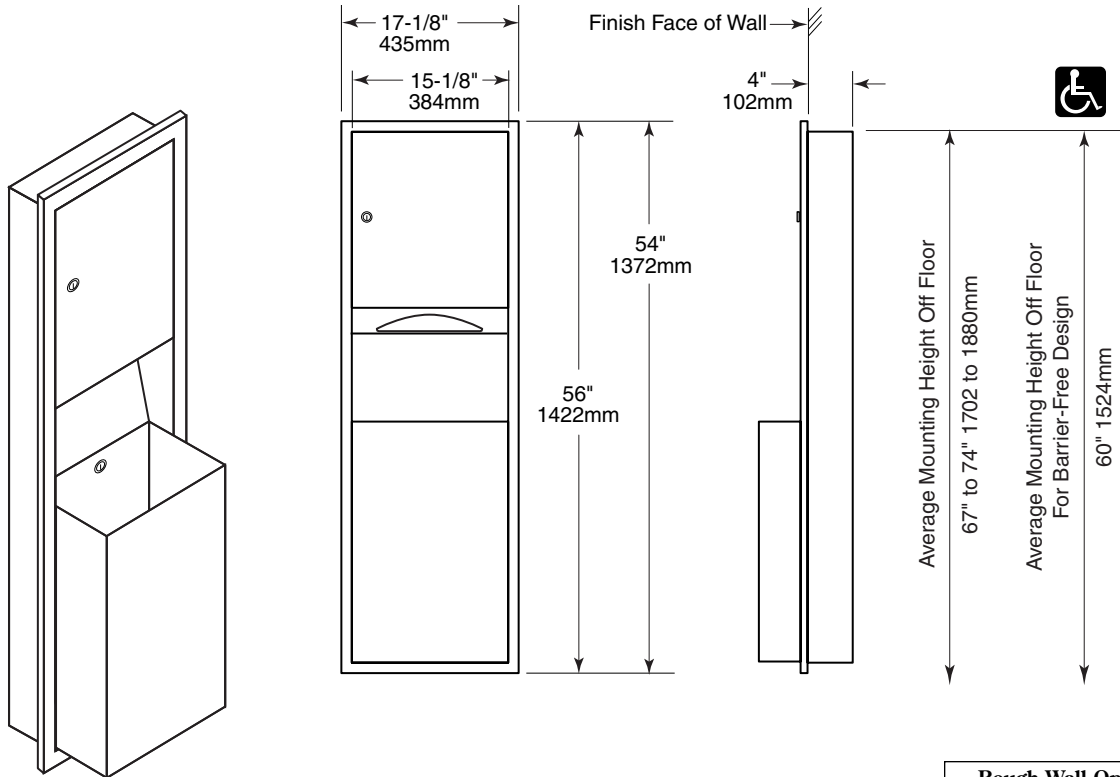

**Rough Wall Opening**  
15-3/4" (400mm) wide  
54-3/4" (1390mm) high  
4" (102mm) minimum  
recessed depth

**CONSTRUCTION:**

Fabricated type 304 heavy-gauge stainless steel. All welded construction with exposed surfaces having a #4 satin-finish. One piece seamless 22-gauge (0.8mm) flange provided with 1/4" (102mm) return for rigidity. EXTRA HEAVY 18-gauge (1.2mm) door, warp free, hung on continuous stainless steel piano hinge, and fitted with tumbler lock. Waste receptacle is 22-gauge (0.8mm) and secured to cabinet with tumbler lock and is removable for servicing; top and bottom edges hemmed for safe handling.

**CAPACITY:**

600 C-fold or 800 Multi-fold towels without use of adapters. Waste receptacle is 12-gallons (45.4-L) capacity.

**ADA GUIDE:**

Access to paper towels should be 15" to 48" (381 to 1219mm) above the finish floor to allow forward and side reach by people in wheelchairs. Units should not project more than 4" (102mm) from the wall.

**Recessed Towel Dispenser and Waste Receptacle Combination shall be Model TW-1 of GAMCO Commercial Restroom Accessories, A Division of Bobrick, One Gamco Place, Durant, OK**