

## TD-6 Coverall Towel Dispenser

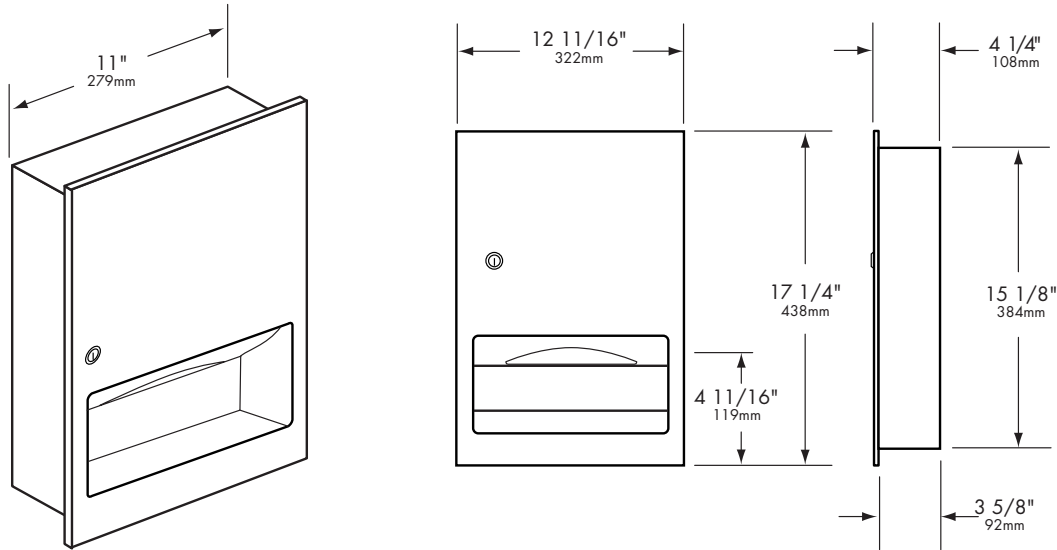

### Construction:

Fabricated of 18-8 type 304 stainless steel with exposed surfaces having a #4 satin finish. One piece seamless door construction, extra heavy 18 gauge (1.2mm) with 5/8" (16mm) return for rigidity. Door is mounted to cabinet with continuous stainless steel piano hinge and is fitted with tumbler lock. All welded construction. 300 C-fold or 400 multi-fold towels capacity.

### Installation:

Provide framed wall opening. Recessed depth required from finish face of wall is 4" (102mm). Check plans and coordinate with mechanical engineer to avoid protrusion from opposite wall, pipes, conduits, electrical wiring etc. If installing in plaster wall recommend grounding. If installing where unit projects above top of wainscot, provide filler to prevent gap from finished wall and flange of unit. Installing in block walls use metal expansion shields.

### Overall Dimensions:

12-11/16"W x 17-1/4"H x 4-1/4"D  
322mm x 438mm x 108mm

### Wall Opening:

11-1/2"W x 15-5/8"H x 3-7/8" minimum depth  
292mm x 397mm x 98mm

### Mounting:

67" (1,702mm) to top of unit, 50" (1,270mm) for handicapped

### ADA Guide:

Access to paper towels should be 15" (381mm) to 48" (1,219mm) above the finish floor to allow for forward and side reach by people in wheelchairs. Hinged panels covering waste receptacle openings should not require more than 5 pounds of force to open. Units should not project more than 4" (102mm) from the wall.

### Options:

TD-6F same as TD-6 except with 2" (51mm) skirt for semi-recessing  
TD-6FS same as TD-6 except with 4" (102mm) skirt for full surface mounting  
PL add "PL" to suffix for phenolic door

*Manufacturer reserves the right to make changes in design or dimensions without formal notice.*