

NV-1ND Sanitary Napkin Vendors

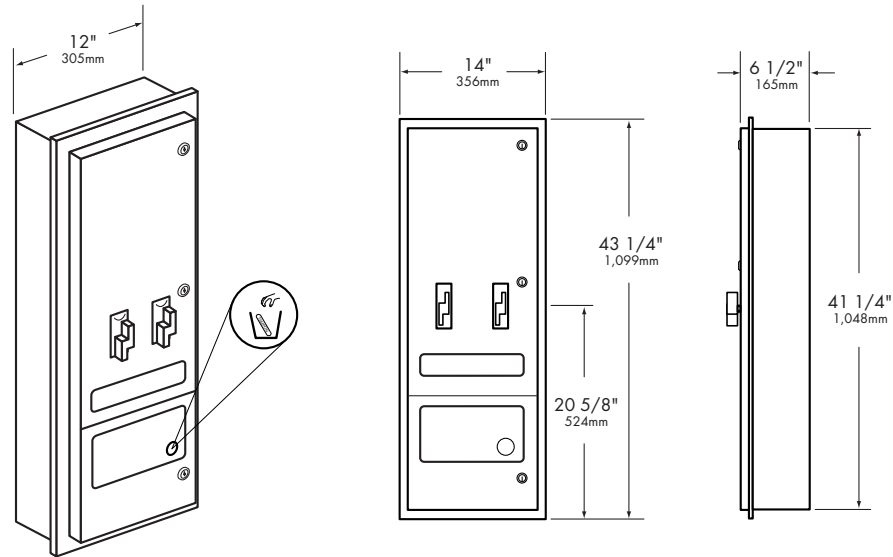

Construction:

Cabinet and flange fabricated of 18-8 type 304 stainless steel. All welded construction with exposed surfaces having a #4 satin finished. Extra heavy 18 gauge (1.2mm) door, warp free, hung on continuous stainless steel piano hinge, and fitted with three tumbler locks. Adjustable frame provided with 1/4" (6mm) return for rigidity. Coin box fitted with tumbler lock keyed differently than door. Coin mechanisms available for 10¢, 25¢, and free operation. All welded construction. Disposal push door mounted on continuous stainless steel piano hinge. Removable container furnished. Capacity 30 napkins and 27 tampons.

Installation:

Provide framed wall opening. Recessed depth required from finish face of wall is 5-7/8" (149mm). Check plans and coordinate with mechanical engineer to avoid protrusion from opposite wall, pipes, conduits, electrical wiring etc. If installing in plaster wall recommend grounding. If installing where unit projects above top of wainscot, provide filler to prevent gap from finished wall and flange of unit. Installing in block walls use metal expansion shields.

Overall Dimensions:

14" W x 43-1/4" H x 6-1/2" D
356mm x 1,099mm x 165mm

Wall Opening:

12-1/2" W x 41-3/4" H x 2" to 5-5/8" min D
318mm x 1,060mm x 143mm

Mounting:

74" (1,880mm) to top of unit, 60" (1,524mm) for handicapped

Options:

NV-1NDFS same as NV-1ND except without frame for surface mounting.

ADA Guide:

Access to paper towels should be 15" (381mm) to 48" (1,219mm) above the finish floor to allow forward and side reach by people in wheelchairs. Hinged panels covering waste receptacle openings should not require more than 5 pounds of force to open. Units should not project more than 4" (102mm) from the wall. Operable with one hand and without tight grasping, pinching, or twisting of the wrist. Activation of lever should not require more than 5 pounds of force when unit is completely filled.

Manufacturer reserves the right to make changes in design or dimensions without formal notice.