

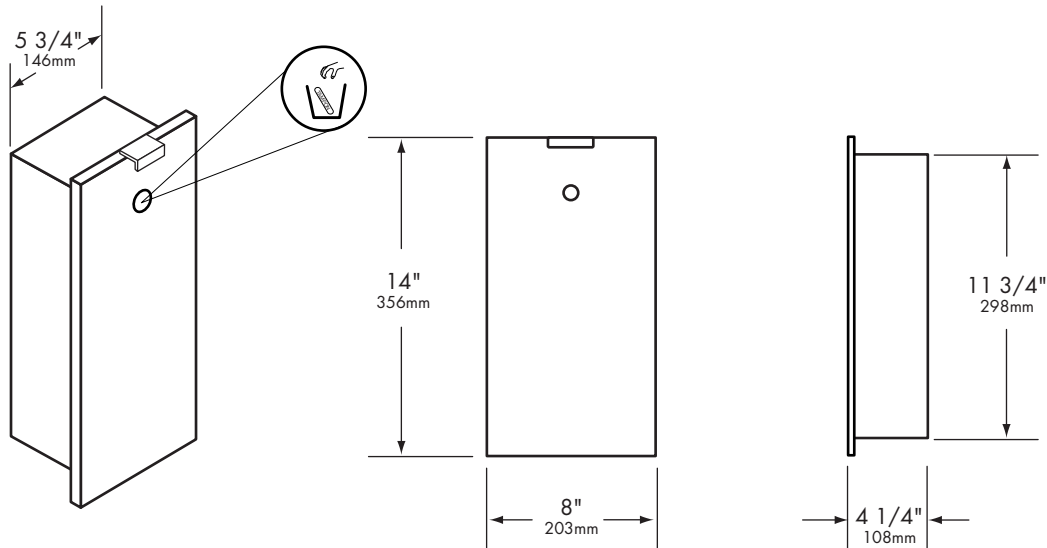

ND-3 Coverall Sanitary Napkin Disposal



Construction:

Fabricated of 18-8 type 304 stainless steel with exposed surfaces #4 satin finished. One piece seamless door construction, extra heavy 18 gauge (1.2mm) with 5/8" (16mm) return for rigidity. Door is mounted to cabinet with continuous stainless steel piano hinge and provided with stainless steel handle, and stainless steel door stop. Stainless steel inner container mounts on front door, and lifts out for servicing. All welded construction.

Capacity:

0.6 gallons (2.3L) removable stainless steel receptacle

Installation:

Provide framed wall opening. Recessed depth required from finish face of wall is 4" (102mm). Check plans and coordinate with mechanical engineer to avoid protrusion from opposite wall, pipes, conduits, electrical wiring etc. If installing in plaster wall recommend grounding. If installing where unit projects above top of wainscot, provide filler to prevent gap from finished wall and flange of unit. Installing in block walls use metal expansion shields. 1/8" (3mm) gap recommended between units for door clearance.

Overall Dimensions:

8"W x 14"H x 4-1/4"D
203mm x 356mm x 108mm

Wall Opening:

6"W x 12"H x 4"D
152mm x 305mm x 102mm

Mounting:

34" (864mm) to top of unit

Options:

ND-3C same as ND-3 except with finger pull handle

Manufacturer reserves the right to make changes in design or dimensions without formal notice.