

Date:

Project Name:

- MS-1** for mop strip, 24" (610mm), 3 holders
- MS-2** for mop strip, 36" (914mm), 4 holders
- MS-3** for mop strip, 48" (1219mm), 5 holders
- MS-4** for mop strip, 60" (1524mm), 6 holders

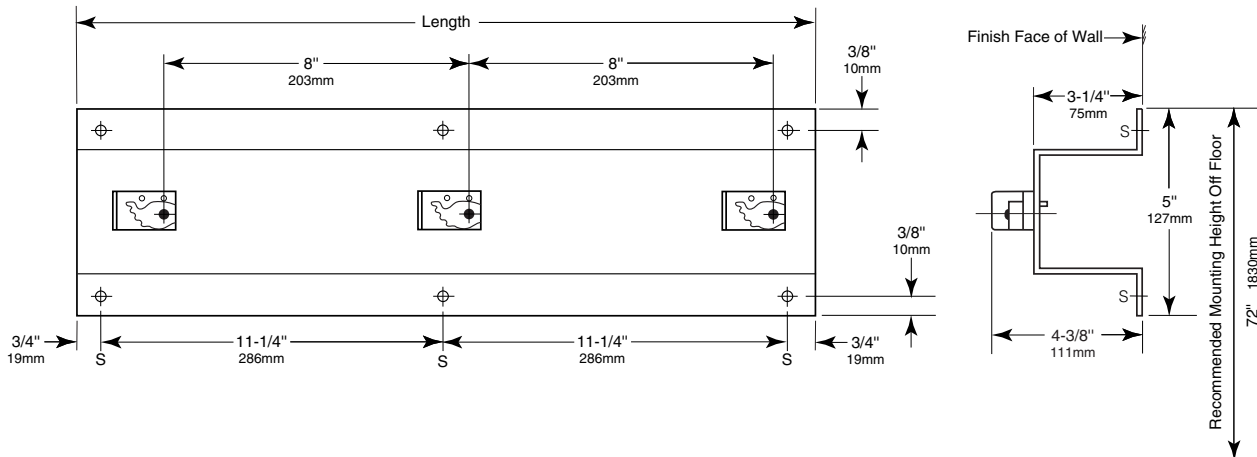
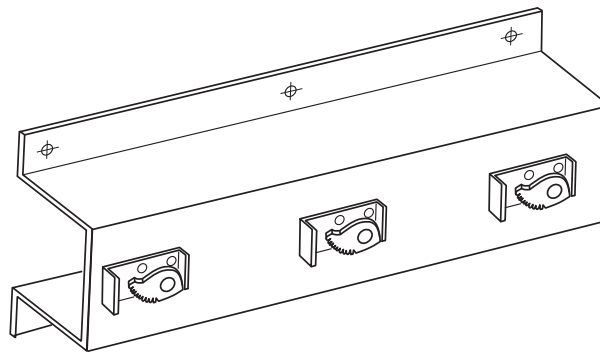

SPECIFICATIONS:

Units fabricated of 20-gauge (.9mm) type 304 stainless steel with exposed surfaces having a satin-finish. Mop holder molded with serrated rubber cam holders and spring loaded to insure maximum gripping ability. Holders accommodate mops and brooms from 3/4" to 1-1/4" (19 to 32mm) in diameter. Large 3-1/4" (83mm) projection keeps mops away from wall.

OVERALL DIMENSIONS:

24" W x 5" H x 3-1/4" D (607 x 127 x 83mm)

Mop Strip shall be Model _____ (insert model number) of Gamco Commercial Restroom Accessories, A Division of Bobrick, One Gamco Place, Durant, OK