

Date:

Project Name:

- | | |
|-------------|--|
| CG-1 | 1-1/2" W x 40" H x 1-1/2" D (28 x 1016 x 38mm) 18-gauge
(1.2mm) adhesive supplied |
| CG-2 | 1-1/2" W x 48" H x 1-1/2" D (28 x 1219 x 38mm) 18-gauge
(1.2mm) adhesive supplied |
| CG-3 | 3-1/2" W x 40" H x 3-1/2" D (89 x 1016 x 89mm) 18-gauge
(1.2mm) adhesive supplied |
| CG-4 | 3-1/2" W x 48" H x 3-1/2" D (89 x 1219 x 89mm) 18-gauge
(1.2mm) adhesive supplied |

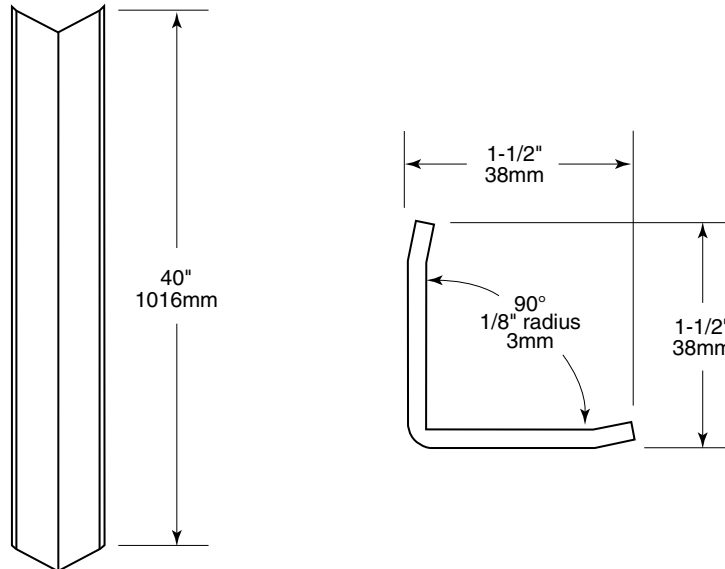

CONSTRUCTION:

Unit fabricated of type 304 HEAVY GAUGE stainless steel with exposed surfaces having a #4 satin-finish. Units bent on a 1/8" (3mm) radius to form a 90° angle. Units provided with huggd edges for safety and to conceal minor wall irregularities.

Furnished with double-faced adhesive tape.

OPTIONS:

Custom styles and sizes available for all corner guards shown above. Stainless steel kick plates and armour plates of all sizes are available.

Corner Guards shall be Model _____ (insert model number) of Gamco Commercial Restroom Accessories, A Division of Bobrick, One Gamco Place, Durant, OK