

Date:

Project Name:

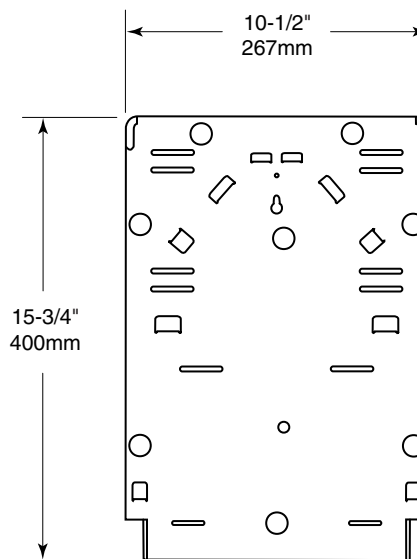
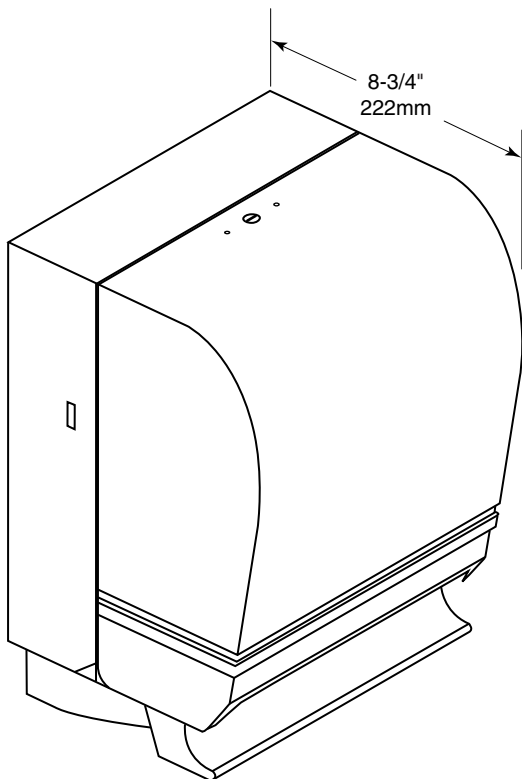

Rear View

CONSTRUCTION:

Heavy gauge steel back and impact resistant plastic front.

CAPACITY:

One (1) - 8" W x 8" D (203 x 203mm) paper roll.

INSTALLATION:

Four (4) #10 x 3/4" (19mm) Phillips pan head machine screws with plastic anchors are provided for installation.

NOTE:

Unit dispenses 5-1/2" (140mm) of toweling with each stroke. Meets ADA requirements. Automatic transfer system allows complete usage of stub rolls up to 4" (102mm) diameter. Unit has a dark transparent plastic front. Double latch lock works with standard metal key.

Push Lever Roll Towel Dispenser shall be Model 161482 of Gamco Commercial Restroom Accessories, A Division of Bobrick, Durant, OK